

# MATRIX 460SFX™

## THE HANDY PREMIUM SEMI-FLUID EP AXLE HUB GREASE

### WHY 460SFX SEMI-FLUID GREASE? **DOUBLES AS A SEALANT.**

Truckers have schedules to keep. Technicians have more profitable jobs to get to. So if the goal is to keep trucks and trailers up and running, you'll need more than regular old axle hub grease.

You'll need an advanced aerospace full-synthetic semi-fluid 00 EP grease that cut its teeth in the gear box.

This stuff sticks to metal and provides a protective coating to inner walls give you an unprecedented level of leak protection. You won't get that from a traditional axle hub grease. *Just from Matrix 460SFX.*

### WHAT MAKES MATRIX 460SFX UNIQUE? **CAULK GUN APPLICATION.**

Matrix 460SFX comes uniquely packaged in a 28 oz. caulk tube. That means technicians can load and lube – reload – and lube again, in no time. Other packaging methods do nothing to help you improve fill times and accuracy:

- Cuts fill times by up to half
- Helps prevent over/under greasing
- Requires less lubricant to fill axle hub than conventional grease
- Coats inner walls for added leak prevention
- Promotes sustainability with recyclable plastic tube

### DOES MATRIX 460SFX COME IN DRUMS OR BUCKETS? **HEAVEN'S NO.**

Both 55-gallon drums and 5-gallon buckets invite waste. Even when deemed “empty,” grease still remains stuck to walls and bottoms inside. And the last thing you want is your high-priced technician scraping it out. With our tubes, you eliminate waste.

Plus, our tubes fit conveniently in cabs and storage compartments, so if a leak occurs on the road, it's handled right then and there. Good luck doing that with a big drum or bucket. *So, yeah, we'll stick with the tubes.*



## AN ADVANCED AEROSPACE FORMULA DESIGNED FOR THE LONG HAUL.

Matrix 460SFX is an advanced aerospace formulation that combines Lithium extreme pressure (EP) complex grease, PAO full synthetic ISO 460 gear lube, and a sophisticated additive package, boosting protection against premature wear, rust, corrosion, and damage:

- Prevents metal-to-metal contact maximizing shock load protection.
- Protects bearings in all operating and ambient temperatures down to as low as -40°F.
- Top fill level is 4 & 8 o'clock requiring less lubricant compared to traditional grease which tops off at 3 & 6.
- Performs in all related applications requiring 100% full-synthetic semi-fluid 00 EP grease.

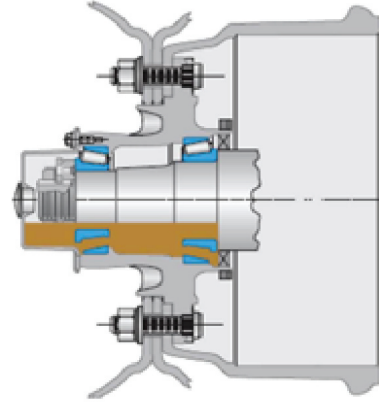

## IT STICKS TO METAL. COATS INNER WALLS. AND LINES POCKETS.

Matrix 460SFX's unique ability to coat the insides and act as a protective sealer is unprecedented. It's protection fleet managers and truck operators want and service shops should stock – that is, if increasing revenue is the objective.

- Matrix 460SFX is great for truck and trailer axle hubs, truck steering (non-drive) axle hubs, and truck wheel (non-drive) axle hubs – provided OEM and TMC RP 631 guidelines are followed.
- Performs consistently within bearing contact surfaces and seals, with high-temperature durability, cooler operation reliability, and reduced friction.
- Use only with factory clean bearings, spindles, axle hub assembly and seals – for best results, use Matrix JamSeal™ push-on wheel seals.

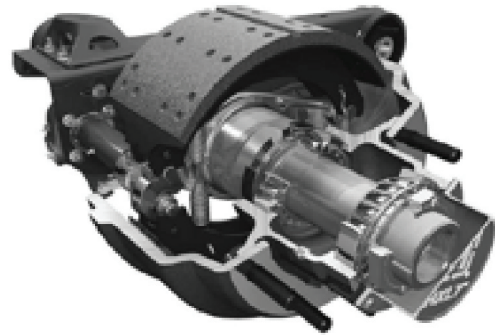

### ARE YOU MATRIX MATERIAL?



Do you champion quality craftsmanship? Are you someone who expects premium-grade parts to be made of premium-grade materials? If so, you're with us. The Matrix Movement is a truckerhood for everyone who wants quality parts to last as long as they used to. Enough with this cheap filler or lesser-grade substitution stuff. You'll only find genuine raw materials in our parts, because who has time to keep changing out cheaper parts? Give us a go at 1-888-411-9916 or go to [Neobrake.com](http://Neobrake.com).